

ZoneTight™, 2-way, Press fit

- For closed cold and warm water systems
- For modulating control of air-handling and heating systems on the water side
- Snap-assembly of the actuator



5-year warranty

Type overview

Type	DN
Z2075QTPF-G	20

Technical data

Functional data	Valve size [mm]	0.75" [20]
	Fluid	chilled or hot water, up to 60% glycol
	Fluid Temp Range (water)	2...100°C [36...212°F]
	Differential pressure	5...50 psi
	Body Pressure Rating	250 psi CWP
	Close-off pressure Δps	200 psi
	Flow characteristic	equal percentage
	Leakage rate	0%
	Angle of rotation note	Operating range 15...90°
	Pipe connection	Press fit
	Installation orientation	upright to horizontal (in relation to the stem)
	Servicing	maintenance-free
	Flow Pattern	2-way
	Controllable flow range	75°
Materials	Valve body	forged brass
	Stem	stainless steel
	Stem seal	EPDM O-ring
	Seat	PTFE, O-Ring EPDM
	Characterized disc	incorporated into the ball
	Diaphragm	EPDM
	O-ring	EPDM
	Ball	stainless steel
Suitable actuators	Non Fail-Safe	CQB(X)
	Electrical fail-safe	CQKB(X)
Terms	Abbreviations	V'nom = nominal flow with valve completely opened V'max = maximum flow, set by the angle of rotation limitation on the actuator

Safety notes



- **WARNING:** This product can expose you to lead which is known to the State of California to cause cancer and reproductive harm. For more information go to www.p65warnings.ca.gov
- If temperature exceeds 212°F operating range due to a boiler control failure the valve will safely contain the hot water but manufacturers product warranty becomes invalid. Valve and actuator replacement is at the expense of others.

Product features

- Application** The PIQCV zone valves with its pressure independent technology are suited for large commercial buildings where higher close-off and dynamic balancing is required. Common applications include unit ventilators, fan coil units, VAV reheat coils, fin tube casing, radiant panels and duct coils. The valve fits in space restricted areas and can be assembled without the use of tools.
- Operating mode** The ball valve is adjusted by a rotary actuator. The actuator is controlled by a commercially available modulating or 3-point control system and moves the ball of the valve – the throttling device – to the position dictated by the control signal. Open the characterized control valve counterclockwise and close it clockwise.
- Flow characteristic** Equal percentage flow control is ensured by the special design of the ball.
- Constant flow volume** With a differential pressure of 16...350 kPa, a constant flow volume is achieved thanks to the integrated pressure regulating valve. Independently of the differential pressure through the valve, a valve authority of 1 is achieved. Even with pressure variations and in the partial load range, the flow rate remains constant with each respective opening position (angle of rotation) and ensures a steady control.

Installation notes

- Permissible installation orientation** The ball valve can be installed upright to horizontal. The ball valve may not be installed in a hanging position, i.e. with the stem pointing downwards.



- Water quality requirements** Belimo valves are regulating devices. For the valves to function correctly in the long term, they must be kept free from particle debris (e.g. welding beads during installation work). The installation of a suitable strainer is recommended.

- Servicing** Ball valves and rotary actuators are maintenance-free.

Before any service work on the control element is carried out, it is essential to isolate the rotary actuator from the power supply (by unplugging the electrical cable if necessary). Any pumps in the part of the piping system concerned must also be switched off and the appropriate slide valves closed (allow all components to cool down first if necessary and always reduce the system pressure to ambient pressure level).

The system must not be returned to service until the ball valve and the rotary actuator have been correctly reassembled in accordance with the instructions and the pipeline has been refilled by professionally trained personnel.

Installation notes

Flow direction The direction of flow, specified by an arrow on the housing, is to be complied with, since otherwise the ball valve could become damaged. Please ensure that the ball is in the correct position (marking on the stem).



Flow setting The angle of rotation of the CQ.. actuator can be changed by end stop clip in 2.5° increments. This is used to set the V'max value (maximum flow rate of the valve).

Remove end stop clip and place at desired position.

After every change of the flow setting by means of end stop clip, an adaptation must be triggered on the modulating actuators.

1. PIQCV

Valve Model (1/2")	Clip Position for Flow Adjustment (GPM)																			
	1	1+	2-	2	2+	3-	3	3+	4-	4	4+	5-	5	5+	6-	6	6+	N-	N	No Clip
Z2050QTPF-B			0.1					0.2			0.3		0.4		0.5		0.6	0.7	0.8	0.9
Z2050QTPF-D	0.2			0.3			0.4	0.5		0.6	0.7	0.8	0.9	1.0	1.2	1.3	1.5	1.6	1.8	2.0
Z2050QTPF-F				0.6		0.7	0.8	0.9	1.0	1.3	1.5	1.7	1.9	2.2	2.5	2.8	3.1	3.3	3.6	4.3
Valve Model 3/4"																				
Z2075QTPF-G			1.6	1.8	2.1	2.4	2.7	3.0	3.3	3.7	4.0	4.4	4.9	5.3	5.8	6.3	6.7	7.2	7.7	9.0
Runtime	30	33	35	37	39	41	43	45	47	49	51	53	55	58	60	62	64	66	68	75

Dimensions

Type	DN	Weight
Z2075QTPF-G	20	4.0 lb [1.8 kg]

Dimensions

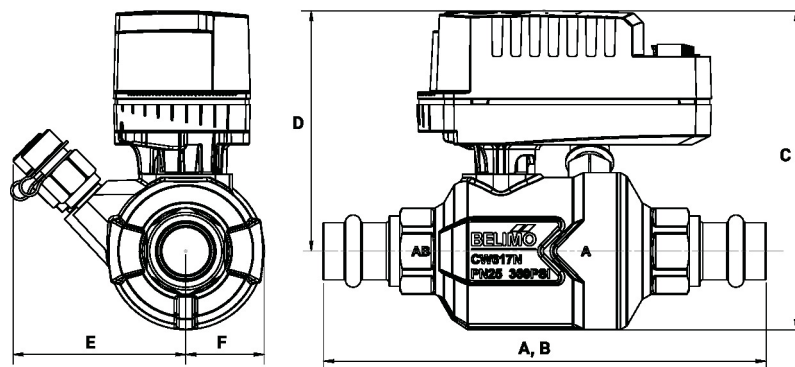

A	B	C	D	E	F
6.7" [171]	6.7" [171]	5.1" [129]	3.5" [89]	2.6" [66]	1.5" [39]

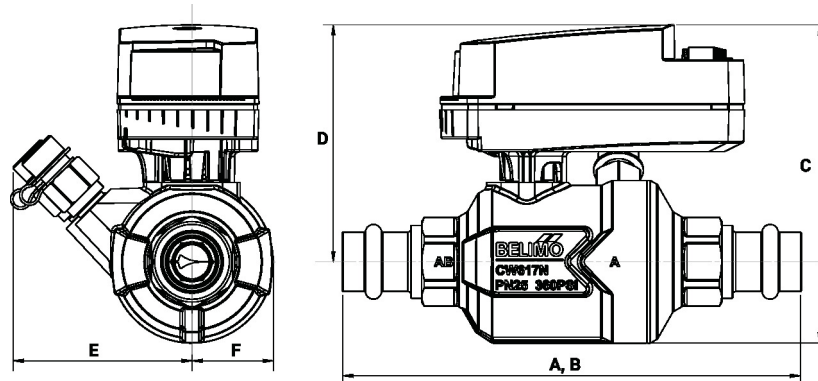

A	B	C	D	E	F
6.7" [171]	6.7" [171]	5.0" [127]	3.5" [89]	2.6" [66]	1.5" [39]

Modulating, Electrical fail-safe, 24 V

- Nominal voltage AC 24 V
- Control Modulating 2...10 V or 0.5...10 V
- Position feedback 2...10 V or 0.5...10 V



5-year warranty



Technical data

Electrical data	Nominal voltage	AC 24 V
	Nominal voltage frequency	50/60 Hz
	Nominal voltage range	AC 19.2...28.8 V / DC 21.6...28.8 V
	Power consumption in operation	2.5 W
	Power consumption in rest position	0.5 W
	Transformer sizing	5 VA
	Electrical Connection	Terminal blocks
	Overload Protection	electronic throughout 0...90° rotation
	Electrical Protection	actuators are double insulated
Functional data	Operating range Y	2...10 V
	Operating range Y note	4...20 mA w/ ZG-R01 (500 Ω, 1/4 W resistor)
	Operating range Y variable	0.5...10 V
	Position feedback U	2...10 V
	Position feedback U variable	0.5...10 V
	Bridging time (PF)	2 s
	Pre-charging time	5...20 s
	Angle of rotation	90°
	Angle of rotation note	adjustable with mechanical stop
	Running Time (Motor)	75 s / 90°
	Running time fail-safe	<60 s
	Noise level, motor	35 dB(A)
	Noise level, fail-safe	35 dB(A)
Position indication	pointer	
Safety data	Power source UL	Class 2 Supply
	Degree of protection IEC/EN	IP40
	Degree of protection NEMA/UL	NEMA 1
	Enclosure	UL Enclosure Type 2
	Agency Listing	cULus acc. to UL60730-1A/-2-14, CAN/CSA E60730-1:02 CE acc. to 2014/30/EU and 2014/35/EU
	Quality Standard	ISO 9001
	UL 2043 Compliant	Suitable for use in air plenums per Section 300.22(C) of the NEC and Section 602 of the IMC
	Ambient humidity	Max. 95% RH, non-condensing
	Ambient temperature	35...104°F [2...40°C]

Technical data

Safety data	Storage temperature	-40...176°F [-40...80°C]
	Servicing	maintenance-free
Weight	Weight	0.41 lb [0.19 kg]
Materials	Housing material	UL94-5VA

Product features

Application Electrical fail-safe proportional ZoneTight actuator.
 Valve selection should be done in accordance with the flow parameters and system specifications. The actuator is mounted directly to the valve without the need for tools or additional linkage.
 The actuator operates in response to a 2...10 V, 0.5... 10 V or 4...20mA control signal.

Electrical installation

INSTALLATION NOTES

- Actuators may be connected in parallel. Power consumption and input impedance must be observed.
- Actuators may also be powered by DC 24 V.
- Only connect common to negative (-) leg of control circuits.
- A 500 Ω resistor (ZG-R01) converts the 4...20 mA control signal to 2...10 V.
- Actuators with plenum cable do not have numbers; use color codes instead.
- Meets cULus requirements without the need of an electrical ground connection.
- Warning! Live electrical components!**
 During installation, testing, servicing and troubleshooting of this product, it may be necessary to work with live electrical components. Have a qualified licensed electrician or other individual who has been properly trained in handling live electrical components perform these tasks. Failure to follow all electrical safety precautions when exposed to live electrical components could result in death or serious injury.

Wiring diagrams

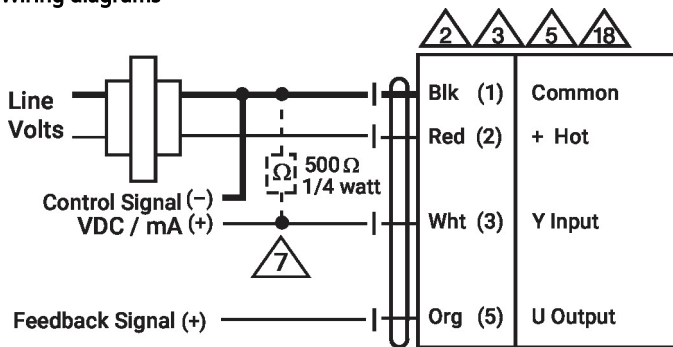

2 VDC	Open	0.5 VDC	Open
10 VDC	Close	10 VDC	Close